

KE 530

3-BUTTON 3-CHANNEL REMOTE CONTROL KEYLESS ENTRY INSTALLATION & OPERATION INSTRUCTIONS

WIRING DIAGRAM

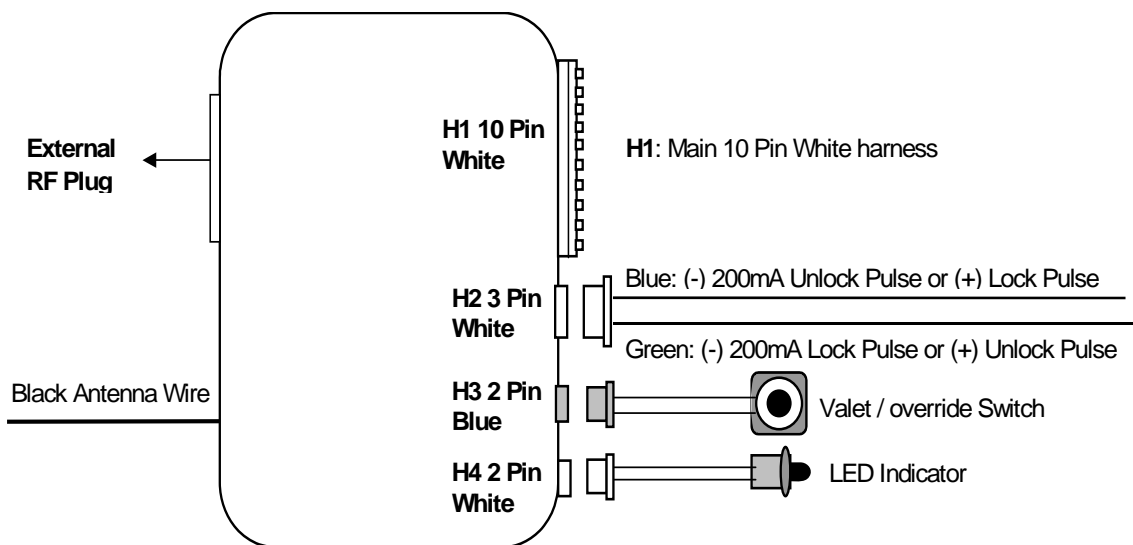

H1: 10 PIN MINI CONNECTOR WIRE HARNESS:

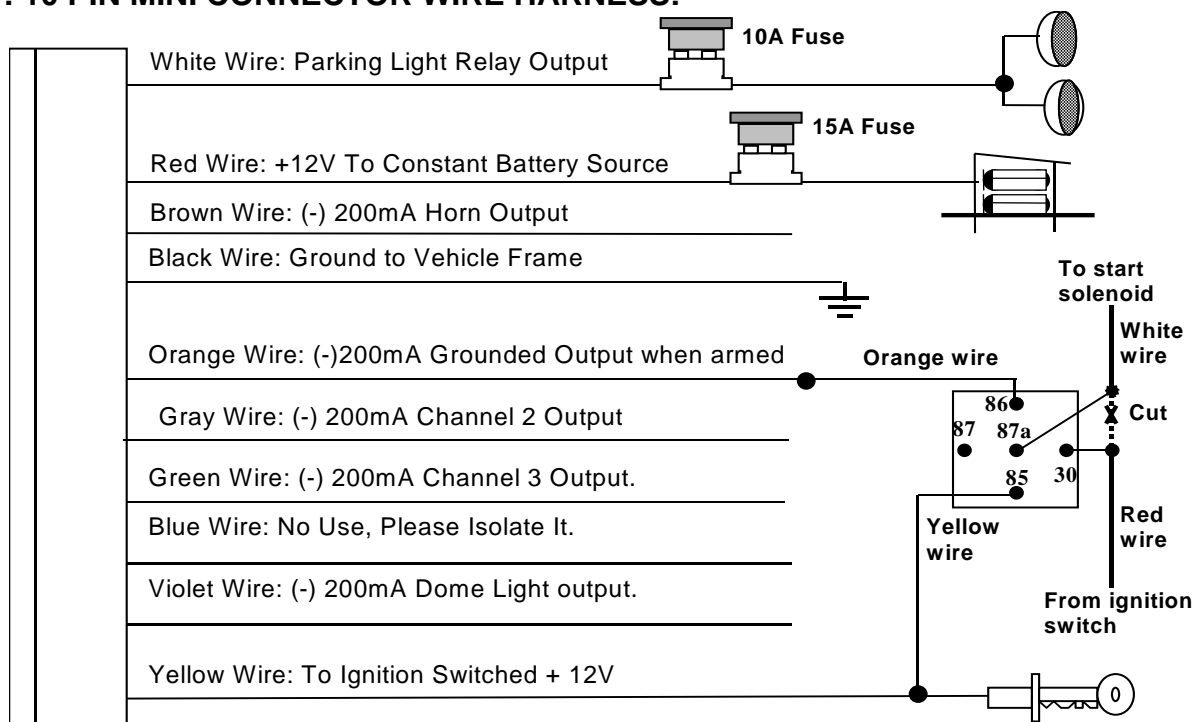

WIRING

Keep wiring away from moving engine parts, exhaust pipes, and high-tension cable. Tape wires that pass through holes on the firewall to prevent fraying. Watch out for sharp edges that may damage wires and cause short circuit.

CAUTION: Do not connect the wire harness to the control module until all wiring to vehicle is complete.

H1. MAIN 10 PIN WIRE HARNESS:

H1/1. White wire – Parking Light Relay Output (+12 V 10A Output) –

Connect the WHITE wire to the parking light wire coming from the headlight switch. Do not connect the WHITE wire to the dashboard lighting dimmer switch. (Damage to the dimmer will result). The limitation of the WHITE wire is 10 Amp max. Do not exceed this limit or damage to the alarm and parking relay will result.

H1/2. Red wire – System Power (+12V Constant) –

The RED wire supplies power to the system. Connect this wire to a constant +12 volt source.

H1/3. Brown wire – (-) 200mA Horn Output –

This wire is provided to use the existing vehicle's horn as the alarm system's optional's warning audible device. It's a transistorized low current output, and should only be connected to the low current ground output from the vehicle's horn switch. When the system is triggered, the horn will sound.

H1/4. Black wire – System Ground –

This is main ground connection of the alarm module. Make this connection to a solid section of the vehicle frame. Do not connect this wire to any existing ground wires supplied by the factory wire loom; make the connection to the vehicle's frame directly.

H1/5. Orange wire – (-) 200mA Grounded Output When Armed –

This wire will become grounded when the alarm is armed. The current capacity of this wire is 200mA. This output can control starter disable, when an intrusion is detected and the system is triggered. The vehicles prevent from any unauthorized starting.

- Find the wire from the starter solenoid, (usually located on the starter) and going to the ignition switch.
- When found, use voltmeter, connect one probe of the voltmeter to ground and connect the other end of the probe to the starter wire, it should receive "12 volts" only when the ignition key in the "START" position.
- After locating the correct wire, cut it in half, try to start the vehicle. The engine should not "crank over".
- When the extend wires are needed, they must be exactly same gauge as the cut wire. Connect the cut wire from the key switch to the RED wire (pin #30) of the relay, and connect the starter wire to the WHITE wire (pin #87a) of the relay.
- Connect the ORANGE Wire from the control module to the ORANGE wire (pin #86) of the relay.
- Connect the Yellow wire (pin #85) of the relay to a switched 12 volts source from the ignition switch.

NOTE: If more than one electronic device will be connected to the ORANGE Wire, it will be necessary to isolate the connection of each device control wires with a 1N4003 diode.

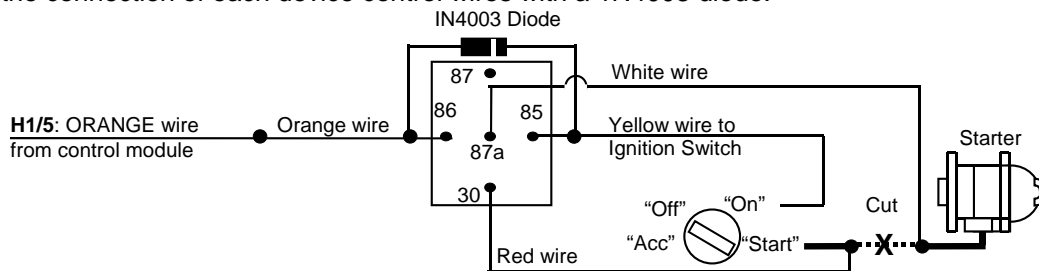

H1/6 . Gray wire – (-) 200mA CHANNEL 2 OUTPUT Output –

This will become a 1 second pulse ground by press and hold the  button on transmitter for two seconds, the current capacity of this wire is 200 mA. this feature allows you to remote control trunk release or other electric device.

H1/7. Green wire – (-) 200mA Channel 3 Output–

This wire will become momentary grounded when you activate channel 3 on the transmitter. The current capacity of this wire is 200mA. This feature can let you to remote control the optional electrical device.

Note: The control unit will keep "On" when the buttons are pressed continuously, and it will "off" when the buttons are released.

H1/8. Blue wire – No Use, Please Isolate It –

H1/9. Violet wire – (-) 200mA Dome Light Control Output –

This wire becomes grounded when the dome light controls circuit active. The current capacity of this wire is 200mA. This wire can control the operation of the interior lights. An optional 10 Amp relay can be used to this system for interior lights operation.

H1/10. Yellow wire – To Ignition Switched +12V –

This wire is connected to a switched 12 volts source. This wire should receive "12 volts" when the ignition key is in the "ON" and "START" position. When the ignition is turned "OFF", this wire should receive "0" voltage.

H5. RF ANTENNA - BLACK THIN WIRE

The black thin wire on control module is the receiver antenna wire. Antenna placement is very important! Ensure that it is unwrapped and stretched out with the last 6" straight and keep it away from large metal objects or chassis for best reception.

H2. 3 PIN DOOR LOCK HARNESS:

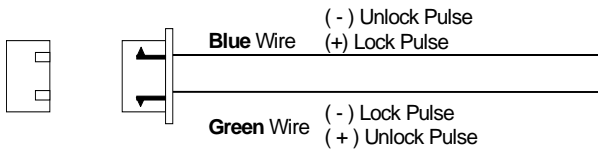

INSTALL NEW DOOR LOCK MOTOR

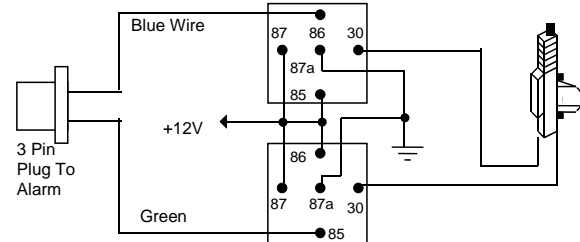

NEGATIVE TRIGGER DOOR LOCK SYSTEM

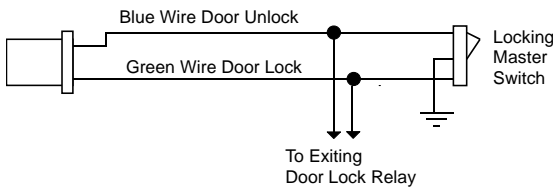

POSITIVE TRIGGER DOOR LOCK SYSTEM

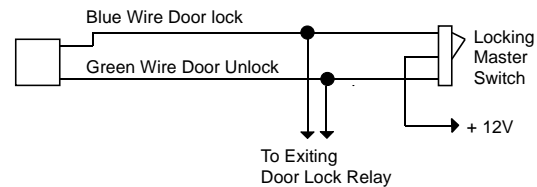

5-WIRE ALTERNATING DOOR LOCK

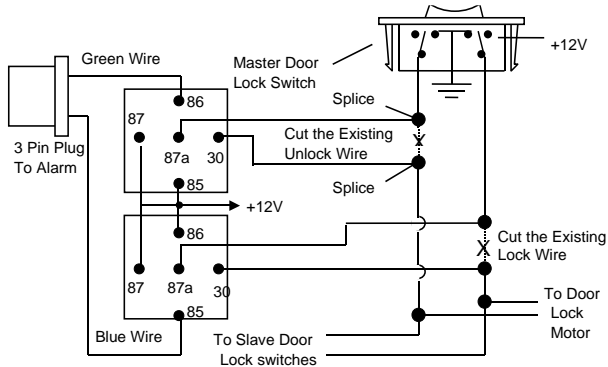

VACUUM OPERATED CENTROL LOCKING

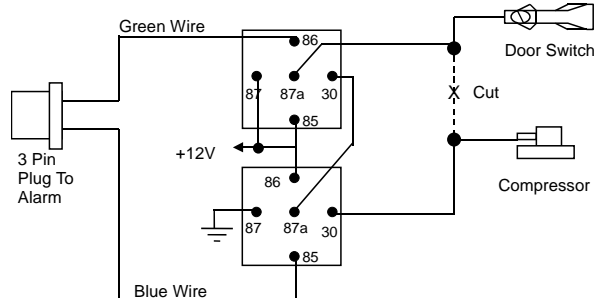

PROGRAMMING

A. THE TRANSMITTERS:

Maximum is 4 transmitters. Two modes of programming, one is designated channel, (Button is door lock/door unlock), the other is auto channel setting. (Button is door lock, button is door unlock)

Enter:

1. Turn the Ignition 'switch to 'ON' position. Within 10 seconds.
- 2-a. Push the Valet switch 3 times to enter designated channel. 1 long and 1 short chirps and the LED pulse flash to confirm you are now in the designated channel-programming mode.
- 2-b. Push the Valet switch 6 times to enter auto channel. 2 long and 1 short chirps and the LED pulse flash to confirm you are now in the auto channel-programming mode.

Program:

3. Press button on one of the transmitter until a chirp from siren / 1 flash from parking light / LED turns on for 2 seconds to responds the transmitter is now programmed.
4. Apply the same procedure (step 3) to program 2nd, 3rd, and 4th

Exit: Turn Ignition to 'OFF' position, or leave it for 10 seconds. A 3 long chirps and the LED turns off to confirm exit.

Note: If more than 4 transmitters programmed, the system only kept the last 4 transmitters.

B. PROGRAMMING SYSTEM FEATURES:

Total 6 programming features to select.

Enter:

1. Turn the Ignition 'switch 'On' then 'OFF' and stay in OFF position.
2. Within 10 seconds, push the Valet switch 6 times and a long chirp is hearing and the LED turns on to confirm you are now in the Alarm feature-programming mode.

Program:

3. Push the valet switch times that equal the feature number you want. Example: Push valet switch 3 times, it's on active/passive arming selection. The siren will chirp 3 times, LED flash 3 times to confirm enter this feature.
4. Select active arming, turn ignition from 'off' to 'on'. 1 chirp for confirmation.
Select passive arming, turn ignition from 'on' to 'off'. 2 chirps for confirmation.
5. If you want to program 2-pulse, unlock off/on feature, when the system is in active / passive arming, push valet switch 3 times again. (Siren chirp 6 times, LED flash 6 times) The system will add on the previous valet switch pushing.

Note: Totally push valet switch 6 times, the siren chirp 6 times, and LED with 6 flashes... pause sequence. If push the valet switch again, the system will exit the program mode, the LED will turn off to confirm exit.









Exit: Push the valet switch 7 times the LED will turn off

Push valet switch times:	Chirp / LED pulse	Turn ignition from 'OFF' to 'ON' One Chirp to confirm Factory Default Setting	Turn ignition from 'ON' to 'OFF' Two Chirps to confirm
1	1	Ignition on/off, door lock/unlock	No
2	2	Passive arming with door lock	No
3	3	Active arming	Passive arming
4	4	Disarm parking light on 30 seconds	No
5	5	Door lock/unlock 0.9 second timer	Door lock/unlock 3.6 seconds timer
*6	6	Without double pulse unlock	Double pulse unlock







OPERATION MANUAL

A. TRANSMITTER OPERATION:

Auto channel

Transmitter Button	System Function	Remark
	Lock Doors	
 (3-second)	Panic Function	Press and Hold for 3 seconds.
	Unlock Doors	
 + 	Silent Lock Doors / Unlock Doors	
 (2-second)	Channel 2 (Trunk) Control Output	Press and Hold for 2 seconds
 + 	Channel 3 Control	

Designated channel

Transmitter Button	System Function	Remark
	Lock / Unlock Doors	
 (3-second)	Panic Function	Press and Hold for 3 seconds.
 + 	Silent Lock Doors / Unlock Doors	
 (2-second)	Channel 2 (Trunk) Control Output	Press and Hold for 2 seconds
	Channel 3 Control	

B. LED INDICATORS:

LED	Status
Off	Disarmed
Slow flash	Armed
Fast flash	Passive arming
On (solid)	Valet mode

C. CHIRP INDICATORS:

Chirp	Function
1 chirp	Lock Doors
2 chirps	Unlock Doors

D. PARKING LIGHT:



Parking light	Function
1 flash	Lock Doors
2 flashes	Unlock Doors
Flash 30 seconds	Panic

E. SYSTEM OPERATING CONDITION:

	Horn	Parking Light	LED	Doors	Starter	Dome Light
1. Lock Doors	1 Chirp	1 Flash	Slow Flash	Locking	Disable	1 Flash
2. Unlock Doors	2 Chirps	2 Flashes	Fast Flash	Unlocking		Turns on for 30-second
3. Panic	Alarming	Flashes	Slow Flash	Locking	Disable	Flashes

F. ACTIVE LOCK & ARM:

1. Press  button on transmitter.
2. The horn will chirp once and parking light will flash once indicating that the vehicle's starter has been disabled (if installed). The vehicle doors will lock upon arming when interfaced with the keyless system.

SILENT ARMING / DISARMING: Press the  +  button together on the transmitter will arm or disarm your keyless system, No chirp sound will be heard, arm / disarm confirmation will be through the vehicles parking lights only.

G. PASSIVE ARMING

Active arming / disarming is controlling your keyless system via the remote transmitter. This keyless system is equipped with an optional Passive Arming feature, which allows the keyless system to arm 60 seconds after the ignition turns off.

1. Turn the ignition to the "OFF" position.
2. The keyless system LED will flash fast for 60 seconds.
3. After 60-second timer has elapsed, the keyless system will automatically "Disable the Vehicle's Starter".
The horn will chirp [1] time and the parking lights will flash [1] time.

PASSIVE DOOR LOCKING: (See Feature Programming)

The vehicle doors will automatically lock after passive arming cycle has been completed.

H. ACTIVE UNLOCK & DISARM:

1. Press  button on the transmitter.
2. The horn will chirp twice and parking light will flash twice to indicating that the vehicle's starter disable device, (where installed) will be enable allowing the vehicle to start. The vehicle doors will unlock and dome light will turn on for 30 seconds upon disarming when interfaced with the keyless entry system.

I. DISARMING WITHOUT A TRANSMITTER

The Override function may be used if the remote transmitter is lost or inoperative.

1. Enter the vehicle and turn the ignition switch to 'ON' position.
2. Within 15 seconds push and release the valet switch

The keyless enter the disarm mode. The vehicle's starter disable device, (where installed) will be enable allowing the vehicle to start.

J. VALET MODE: (System in Disarm or Valet mode)

The valet switch allows you to temporarily bypass starter disable & passive arming function, eliminating the need to hand your transmitter to parking attendants or garage mechanics. When the system is in valet mode, all starter disable & passive arming function are bypassed, however the remote panic feature and remote door locks will remain operational.

Enter Valet Mode:



1. Turn the ignition to "ON" position.
2. Push and hold valet switch for 2 seconds until the LED turns on. The LED will remain on as long as the system is in 'valet mode'.

Exit Valet Mode:

1. Return to normal operation, turn ignition 'on'.
2. Push and hold valet switch for 2 seconds, The LED will turn off indicate the system are exiting the valet mode.

L. PANIC FUNCTION:

The transmitter can be used as a remote panic switch to manually trigger the alarm in case emergency.

1. Press and hold the  button on the transmitter for 3 second. The alarm will immediately sound.
2. To stop the alarm, press the unlock () button on the transmitter.
3. If the unlock button is not pressed, the alarm will automatically stop after 30 seconds.

O. DOME LIGHT CONVENIENCE DELAY & SUPERVISION

The keyless system with a unique feature, which will turn on your vehicle dome light as following:

1. Upon disarming, the interior lights will remain on for 30 seconds.
2. If the vehicle is intruded, the interior light will flash for 30 seconds.

Note: Turn ON the ignition switch or arm the alarm will turn off the dome light.



P. IGNITION CONTROL DOOR LOCKS. (See Feature Programming.)

If the vehicles door locks have been interfaced to the security system, the system will automatically lock the vehicle's doors when the ignition is turned "ON" and /or unlock the vehicle's doors when the ignition is turned "OFF".

Q. TRUNK RELEASE CONTROL OUTPUT.

Press and hold the trunk () button on transmitter for two seconds to remote control the trunk release or other electric devices.

R. CHANNEL 3 TIMER CONTROL OUTPUT

Press the channel 3 ( + ) button on the transmitter to active Channel 3 function. The device will 'on' when the button press continuously, and 'off' when the button released.

This device complies with part 15 of the FCC rules. Operation is subject to the following two conditions.

- (1) This device may not cause harmful interference, and
- (2) This device must accept any interference received, including interference that may cause undesired operation.

MEGATRONIX
CALIFORNIA, U.S.A.