

MEGATRONIX

TP22

Anti-Code Grabbing Wireless Transponder Immobilizer Security System



MEGATRONIX

CALIFORNIA, U.S.A.

Introduction

Congratulations on purchasing the immobilizer system. This high-tech immobilizer uses the latest in transponder technology to protect automatically your vehicle from theft. Once installed, disarming of the immobilizer is fully automatic and requires no action on the part of the user. It has three points of immobilization as well as a negative armed output option.

Operation

One of the transponder tags should be attached to the key ring containing the vehicle's ignition key. It is important that only one tag be attached to the key ring at any given time. The other tag should be kept separately as a spare or attached to the vehicle's spare set of keys.

The immobilizer will automatically search for tags for the first 60 seconds after the driver's door is opened or the ignition is turned on. When a correct transponder tag is recognized, the LED will stop flashing, indicating the immobilizer is disarmed.

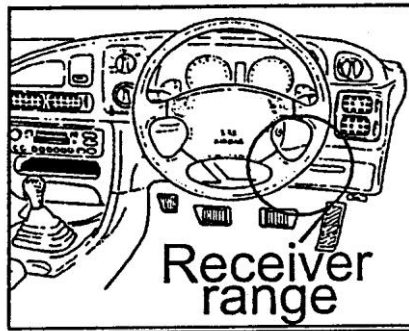

The immobilizer will re-arm automatically 30 seconds after the ignition has been turned off. During the automatic arming period, the LED will flash rapidly. Once armed, it will flash slowly.

Emergency Override

This immobilizer is equipped with a high security emergency override system. The override is based on a PIN (Personal Identification Number) that must be entered through the ignition switch in the event that a tag is lost. The PIN is entered by following the instructions below. All units when shipped have a different PIN number with a sticker on the services card. A new PIN number is programmable; please see **Changing PIN Number** further in the instructions.

To demonstrate, the override PIN number of 1-2-3-4 will be used. It is important to read and understand the following instruction before beginning the override procedure.

Override is based on a combination of turning the ignition on and off, and counting the flashes from the red LED. If a mistake is made, simply start the procedure again with the first digit.

Below procedure assumes the PIN is 1-2-3-4. Ensure no tag is in range of receiver (Ignition switch).

	Action	Reaction	Result
1	Turn ignition switch ON	LED steady glow	
2	Turn ignition OFF and count flashes	LED flashes	
3	After ONE flash turn ignition ON	LED steady glow	PIN #1 Entered
4	Turn ignition OFF and count flashes	LED flashes	
5	After TWO flashes turn ignition ON	LED steady glow	PIN #2 Entered
6	Turn ignition OFF and count flashes	LED flashes	
7	After THREE flashes turn ignition ON	LED steady glow	PIN #3 Entered
8	Turn ignition OFF and count flashes	LED flashes	
9	After FOUR flashes turn ignition ON	LED flashes quickly	PIN #4 Entered
10	Leave ignition ON - Immobilizer will override after 15 seconds	LED will extinguish	

The immobilizer will remain overridden until ignition is switched ON and a valid tag is within range of receiver (ignition key); where the LED will flash rapidly as per auto-arming cycle.

Programming a New PIN Number

Changing PIN from 1-2-3-4 to 4-3-2-1. Ensure no tag is in range of receiver (Ignition switch).

	Action	Reaction	Result
1	Turn ignition switch ON	LED steady glow	
2	Turn ignition OFF and count flashes	LED flashes	
3	After ONE flash turn ignition ON	LED steady glow	PIN #1 Entered
4	Turn ignition OFF and count flashes	LED flashes	
5	After TWO flashes turn ignition ON	LED steady glow	PIN #2 Entered
6	Turn ignition OFF and count flashes	LED flashes	
7	After THREE flashes turn ignition ON	LED steady glow	PIN #3 Entered
8	Turn ignition OFF and count flashes	LED flashes	
9	After FOUR flashes turn ignition ON	LED flashes quickly	PIN #4 Entered
10	Switch ignition OFF before 5 seconds	LED flashes	

At this point, the immobilizer new PIN is ready to be reprogrammed.

11	After FOUR flashes turn ignition ON	LED steady glow	
12	Turn ignition OFF and count flashes	LED flashes	
13	After THREE flashes turn ignition ON	LED steady glow	
14	Turn ignition OFF and count flashes	LED flashes	
15	After TWO flashes turn ignition ON	LED steady glow	
16	Turn ignition OFF and count flashes	LED flashes	
17	After ONE flash turn ignition ON	LED steady glow	
18	Within 5 seconds show valid tag to receiver (Ignition switch)	New PIN report	

The immobilizer will now report the newly programmed PIN by flashing each number in sequence, each one separated by a long flash.

- 1) Leave ignition ON until report finishes enabling new PIN; OR
- 2) Turn ignition OFF prior to finishing report to forget new PIN and revert back to old PIN.

It is important to record the new PIN number for future use. If a mistake is made and the PIN cannot be remembered, enter the PIN 9-9-9-9 and then bring one of the coded tags close to the ignition switch. This will reset the PIN to 1-2-3-4.

Programming a New Tag to the System

Assume the PIN is still 1-2-3-4. Ensure no tag is in range of receiver (Ignition switch).

	Action	Reaction	Result
1	Turn ignition switch ON	LED steady glow	
2	Turn ignition OFF and count flashes	LED flashes	
3	After ONE flash turn ignition ON	LED steady glow	PIN #1 Entered
4	Turn ignition OFF and count flashes	LED flashes	
5	After TWO flashes turn ignition ON	LED steady glow	PIN #2 Entered
6	Turn ignition OFF and count flashes	LED flashes	
7	After THREE flashes turn ignition ON	LED steady glow	PIN #3 Entered
8	Turn ignition OFF and count flashes	LED flashes	
9	After FOUR flashes turn ignition ON	LED flashes quickly	PIN #4 Entered

At this point, the immobilizer new tag is ready to be reprogrammed.

10	Within 5 seconds place tag into receiver area (Ignition Switch)	LED will glow constantly for TWO seconds	Tag is now confirmed
11	Repeat step 10 for any more tags		

NOTE: *The immobilizer contains enough memory to store five tags. When a sixth tag is programmed, the unit will cycle around and overwrite tag #1. This feature is useful when re-programming the system after tags are either lost or stolen.*

12	Once LED is glowing constantly, switch the ignition OFF. Unit is now armed and will respond to new tag	LED flashes then glows constantly	
----	--	-----------------------------------	--

In the event that both tags are lost and the system is overridden, the immobilizer must be brought out of override before a new transponder can be programmed. Open the driver's door, turn the ignition ON and then bring the new un-coded transponder close to the ignition. Allow 30 seconds for immobilizer to re-arm and begin programming procedure.

WIRING DIAGRAM

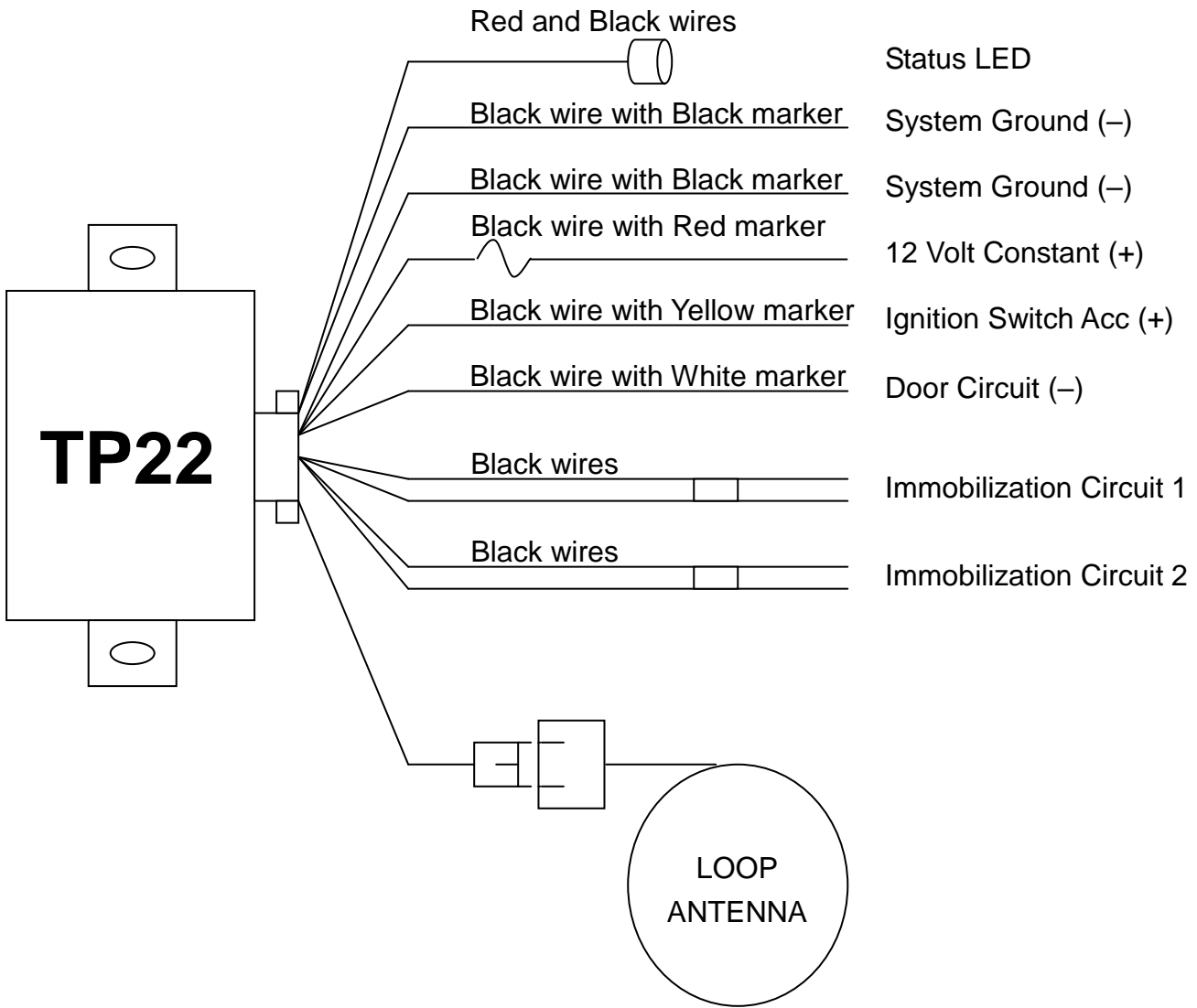

ANTENNA INSTALLATION

1. Antenna can be installed in the vicinity position of the ignition lock, but do not place it too close to the ignition's metal parts so as to get better range as shown below:

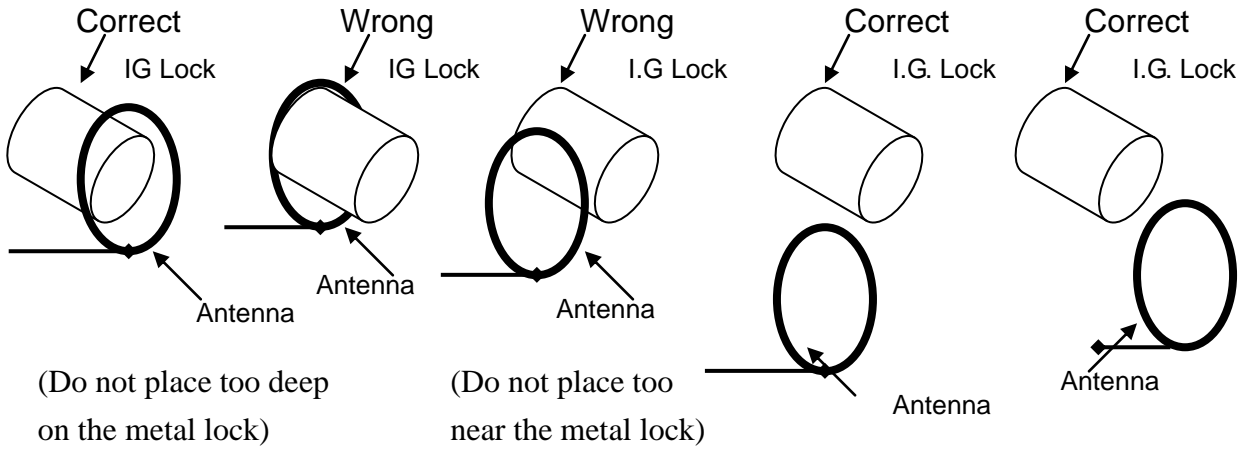

2. Antenna must be installed as an even circular shape. Do not install bended such as below:



3. Please place the antenna as a 90° angle with the direction of the tag how the user usually approaches the tag's antenna to get maximum range (5 to 6 inches) as below:

Poor Range:
 Just 2 or 3 cm for 0° angle and 7 or 8 cm for 30° angles

Long Range:
 12 to 15 cm for 90° angle

