

MEGALARM®

MEGA 462

DELUXE 3-CHANNEL
CAR ALARM SECURITY SYSTEM

Installation And Operation Manual



MEGATRONIX
CALIFORNIA, U.S.A.

WIRING DIAGRAM

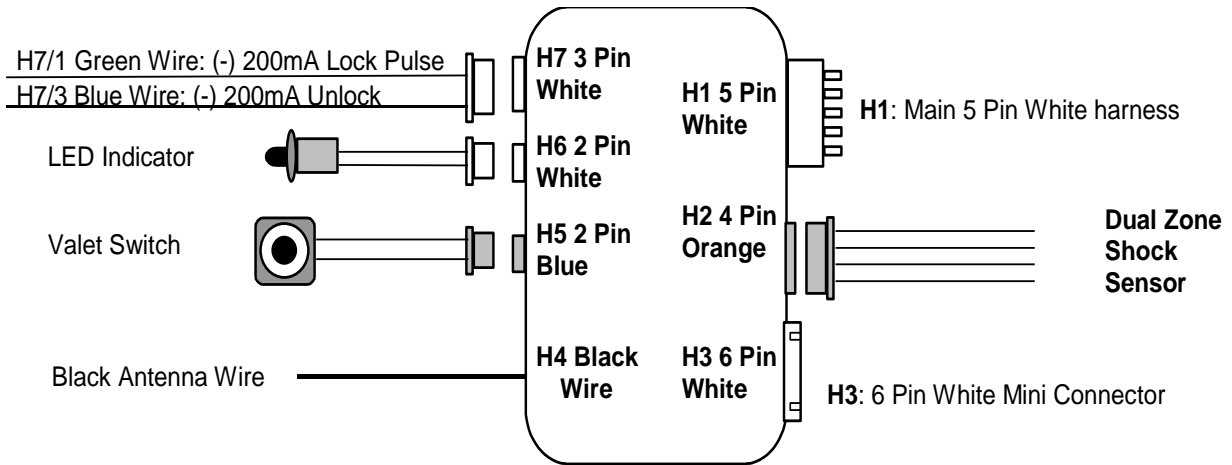

H1: MAIN 5 PIN WIRE HARNESS:

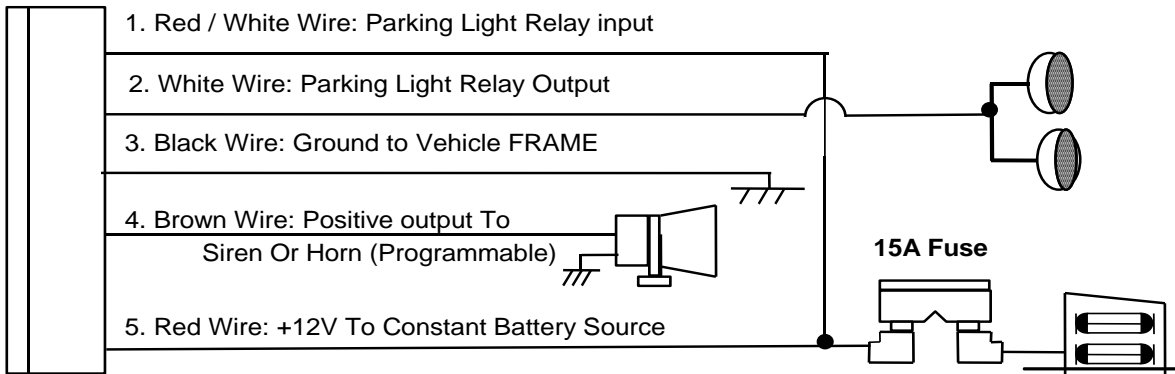

H3: 6 PIN MINI CONNECTOR WIRE HARNESS:

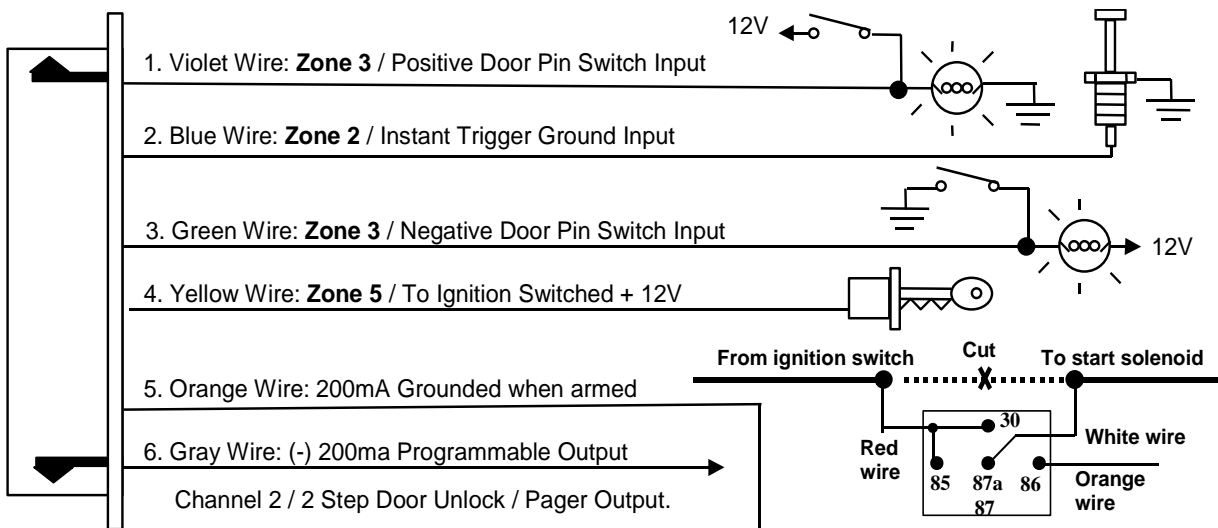

WIRING

Keep wiring away from moving engine parts, exhaust pipes and high-tension cable. Tape wires that pass through holes on the firewall to prevent fraying. Watch out sharp edges that may damage wires and causes short circuit.

CAUTION: Do not connect the wire harness to the control module until all wiring to vehicle is complete.

H1: MAIN 5 PIN WIRE HARNESS:

H1/1. RED / WHITE WIRE – PARKING LIGHT RELAY INPUT --

The RED/WHITE wire is the input to the flashing parking light relay. The connection of the RED/WHITE wire will determine the output polarity of the flashing parking light relay.

If the vehicle you are working on has +12volt switched parking lights, you don't need connect this wire.

This wire already connected to +12volt.

If the vehicle's parking lights are ground switched, cut the RED/WHITE wire, connect the RED/WHITE to chassis ground.

H1/2. WHITE WIRE -- PARKING LIGHT RELAY OUTPUT (+12 V 10A OUTPUT) --

Connect the WHITE wire to the parking light wire coming from the headlight switch. Do not connect the white wire to the dashboard lighting dimmer switch. (Damage to the dimmer will result). The limitation of the white wire is 10 AMP max. Do not exceed this limit or damage to the alarm and parking relay will result.

H1/3. BLACK WIRE -- SYSTEM GROUND –

This is main ground connection of the alarm module. Make this connection to a solid section of the vehicle frame. Do not connect this wire to any existing ground wires supplied by the factory wire loom, make the connection to the vehicle's frame directly.

H1/4. BROWN WIRE -- SIREN DRIVE OR HORN OUTPUT -- (Set Feature III – 1 Programming)

SIREN DRIVE OUTPUT (Factory default setting)

This is the positive (+) output connection for the siren. Current capacity is 2 amps. Make connection to the (+) red wire from the siren. Make the (-) black wire coming from the siren to a good chassis ground.

(+) LOW CURRENT HORN OUTPUT -- (Set Alarm Feature III – 1 To Horn Output)

This wire is provided to use the existing vehicle's horn as the alarm system's optional's warning audible device. It's a transistorized low current output, and should only be connected to the low current positive (+) output from the vehicle's horn switch.

H1/5. RED WIRE -- SYSTEM POWER (+12V CONSTANT) --

The RED wire supplies power to the system. Connect this wire to a constant +12 volt source.

H2: 4 PIN ORANGE CONNECTOR FOR 2 STAGE SHOCK SENSOR



Function: Allows easy positive, negative, instant trigger, and warn-away trigger connection with quick disconnect ability for other detection devices.

H3: 6-PIN MINI CONNECTOR WIRE HARNESS.

H3/1. VIOLET WIRE -- POSITIVE DOOR SWITCH SENSING INPUT--

This wire is the positive trigger input wire for positive door pin switch. This wire is connection for "positive" type factory door pins (typical FORD MOTOR). Locate the "common wire" for all door pins and make the connection of the Violet Wire here.

H3/2. BLUE WIRE -- GROUND INSTANT TRIGGER INPUT --

This wire is the ground trigger input wire for hood/trunk pin switches.

H3/3. GREEN WIRE -- NEGATIVE DOOR SWITCH SENSING INPUT --

This wire is the ground trigger input wire for negative door pin switch. This wire is connection for "grounding" type factory door pins locate the "common wire" that connects the door pin switches. Make the connection of the Green Wire here.

H3/4. YELLOW WIRE – TO IGNITION SWITCHED +12V --

This wire is connected to a switched 12 volts source. This wire should receive "12 Volts" when the ignition key is in the "ON" and "START" position. When the ignition is turned "OFF", this wire should receive "0" voltage.

H3/5. ORANGE WIRE – (-) 200mA GROUNDED OUTPUT WHEN ARMED --

This wire will become grounded when the alarm is armed. The current capacity of this wire is 200mA. This output can control starter disable, when an intrusion is detected and the system is triggered. The vehicles prevent from any unauthorized starting.

a). Find the wire from the starter solenoid, (usually located on the starter) and going to the ignition switch.

- b). When found, use voltmeter, connect one probe of the voltmeter to ground and connect the other end of the probe to the starter wire, it should receive "12 Volts" only when the ignition key in the "START" position.
 - c). After locating the correct wire, cut it in half, try to start the vehicle. The engine should not "crank over".
 - d). When the extend wires are needed, they must be exactly same gauge as the cut wire. Connect the cut wire from the key switch to the RED wire (pin #30) of the relay, and connect the starter wire to the WHITE wire (pin #87a) of the relay.
 - e). Connect the H3/5 ORANGE Wire from the control module to the ORANGE wire (pin #86) of the relay.
- NOTE: If more than one electronic device will be connected to the H3/5 ORANGE Wire, it will be necessary to isolate the connection of each device control wires with a 1N4003 diode.

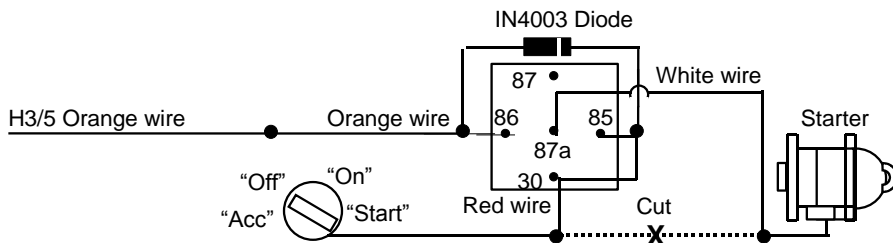

H3/6 . GRAY WIRE – (-) 200mA PROGRAMMABLE OUTPUT – CHANNEL 2 OUTPUT (Factory default setting)

This will become a 1 second pulse ground by press and hold the button II on transmitter for two seconds, the current capacity of this wire is 200 mA. this feature allows you to remote control trunk release or other electric device.

2 STEPS UNLOCK OUTPUT (Set Feature III – 2 Programming to “2 Step Door Unlock Output)

The 2 steps unlock feature will work for the most fully electronic door lock circuit. The vehicle must have an electronic door lock switch (not the lock knob or key switch), which locks and unlocks all of vehicle's doors. When wired for this feature, press the button II one time will disarm the alarm and unlock the driver's door only. If, press button II two times within 3 seconds, the alarm will disarm and all doors will unlock.

PAGER OUTPUT (Set Feature III – 2 Programming to “PAGER Output)

This wire provides a negative output, when the alarm triggered. The current capacity of this wire is 200mA. For optional electrical device in this system, please connected to an additional relay. (I.E. Pager interface....)

H4: RF ANTENNA - BLACK THIN WIRE

The black thin wire on control module is the receiver antenna wire. Antenna placement is very important! Ensure that it is unwrapped and stretched out with the last 6" straight and keep it away from large metal objects or chassis for best reception.

H7: 3 PIN DOOR LOCK CONNECTOR:

3 Pin Mini-Molex Connector

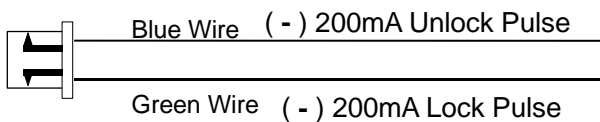

INSTALL NEW DOOR LOCK MOTOR

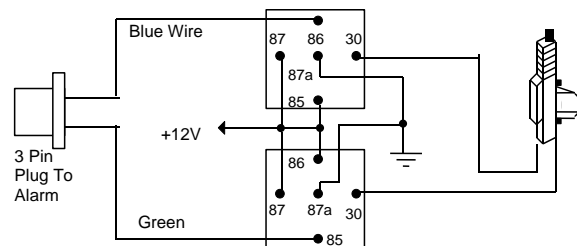

NEGATIVE TRIGGER DOOR LOCK SYSTEM

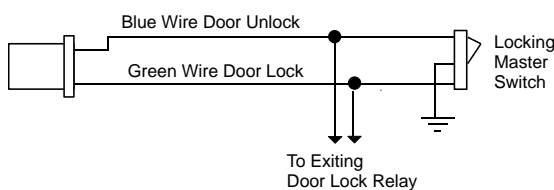

POSITIVE TRIGGER DOOR LOCK SYSTEM

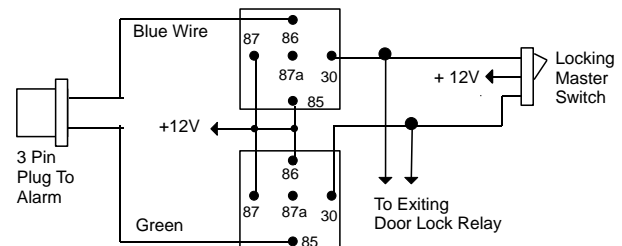

5-WIRE ALTERNATING DOOR LOCK

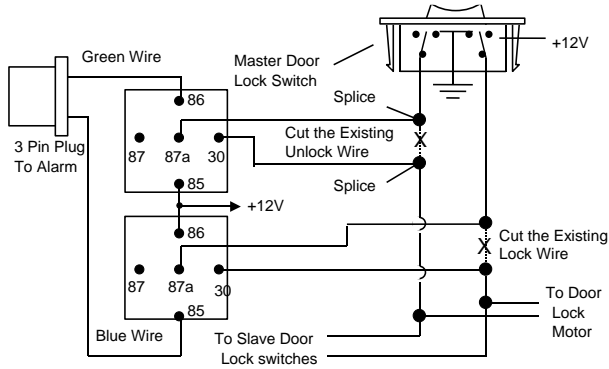

2 STEP DOOR UNLOCK WIRE CONNECTION FOR 5 WIRE ALTERNATING DOOR LOCKS

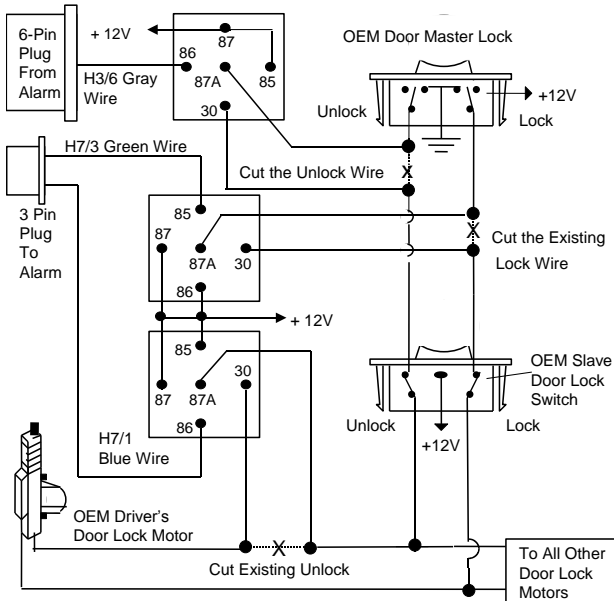

2 STEP DOOR UNLOCK WIRE CONNECTION FOR GROUND SWITCHED DOOR LOCKS

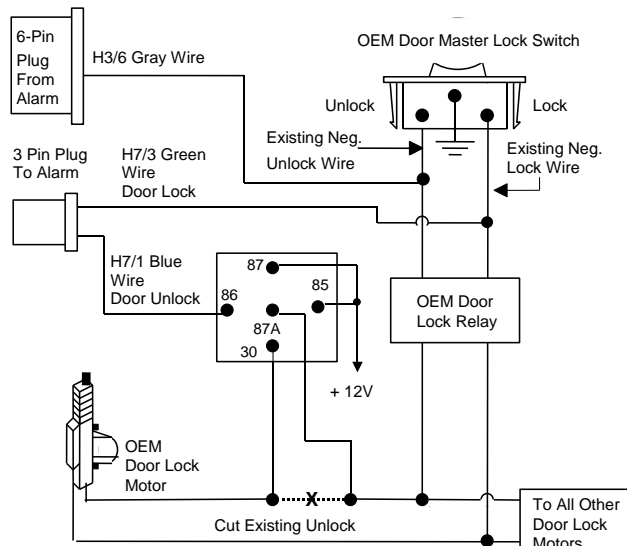

VACUUM OPERATED CENTRAL LOCKING

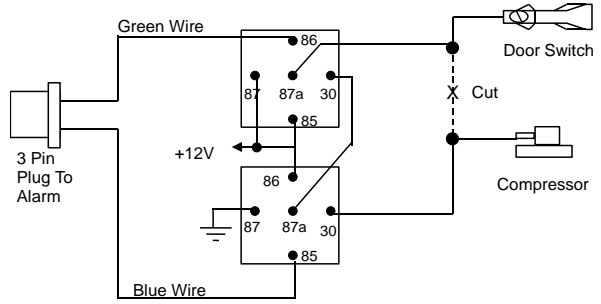

VACUUM OPERATED DOOR LOCKING SYSTEM: TYPICAL OF MERCEDES BENZ AND AUDI.

Locate the wire under the driver's kick panel. Use the voltmeter connecting to ground, verify that you have the correct wire with the doors unlocked, the voltmeter will receive "12 volts". Lock the doors and the voltmeter will read "0 volt". Move the alligator clip to +12V and the voltmeter will receive "12 volts". Cut this wire and make connections. Be sure to program door lock timer to 3 seconds. (See Feature II - 1 Programming.)

2 STEP DOOR UNLOCK WIRE CONNECTION FOR POSITIVE SWITCHED DOOR LOCKS

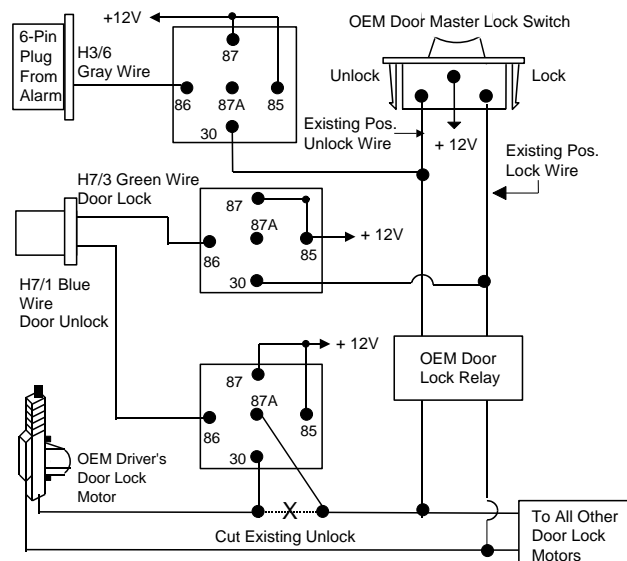

PROGRAMMING

A. PROGRAMMING TRANSMITTER:

Enter:

1. Turn the Ignition switch 'OFF/ON' 3 TIMES and stay in ON position. Within 15 seconds.
2. Push the Valet switch 3 times and hold it until a long chirp is hearing then release the valet switch. You are now in the Transmitter programming mode.

Program:

1. Press button on one of the transmitter until the siren respond with a confirming chirp the first transmitter is now programmed.
2. Press button on the second transmitter until the siren respond with a confirming chirp, the second transmitter is now programmed.
3. Apply the same procedure to program 3rd and 4th

Exit: Turn Ignition to 'OFF' position, or leave it for 15 seconds. A 3 long chirps to confirm exit.

Note: If more than 4 transmitters programmed, the system only kept the last 4 transmitters.

B. ALARM FEATURES PROGRAMMING:

ALARM FEATURE "I" PRORAMMING:

1. Turn the Ignition 'switch 'ON/OFF' 3 TIMES and stay in OFF position.
2. Push the Valet switch **2** times and hold it until **one** chirp and a long chirp is hearing then release the valet switch. You are now in the Alarm feature 'I' programming mode.
3. Press and release the transmitter button 'A' corresponding to the feature 'A' you want to program.
 - a. The siren chirps and LED pause will indicate the latest setting.
 - b. The factory default setting is always [1] LED flash, [1] chirp.
4. Depress the transmitter button 'A' to change the feature. Simple re-depressing the transmitter button 'A' again until the module advances to your desired setting.
 - a. In this case, Press button 'A' again, the module would advance to [2] LED flash, [2] chirp. Press button 'A' again, the module would advance to [3] LED flash, [3] chirps etc.
 - b. Depress the transmitter button 'B' corresponding to the feature 'B' you wants to program.

Press Transmitter Button	One Chirp / LED one pulse Factory Default Setting	Two Chirps / LED two pulse
1. Button I	Chirps on	Chirps off
2. Button II	Automatic Rearm On	Automatic Rearm Off
3. Button I + II	With Door Ajar error chirp.	Bypass Door Ajar error chirp

Exit: Turn Ignition to 'ON' position, or leave it for 15 seconds. A 3 long chirps to confirm exit.

ALARM FEATURE "II" PRORAMMING:

- 1 Turn the Ignition 'switch 'ON/OFF' 3 TIMES and stay in OFF position.
- 2 Push the Valet switch **4** times and hold it until **two** chirps and a long chirp is hearing then release the valet switch. You are now in the Alarm feature 'II' programming mode.
- 3 Press and release the transmitter button 'A' corresponding to the feature 'A' you want to program.

Press Transmitter Button	One Chirp / LED one pulse Factory Default Setting	Two Chirps / LED two pulse	Three Chirps / LED three pulse
1 Button I	0.9-second Door lock pulses.	3.0-second Door lock pulse.	Double pulse unlock
2 Button II	Active arming	Passive arming without passive door locking	Passive arming with passive door locking.
3 Button I + II	Ignition controlled door locks & unlocks	Without ignition controlled door locks & unlocks	

Exit: Turn Ignition to 'ON' position, or leave it for 15 seconds. A 3 long chirps to confirm exit.

ALARM FEATURE "III" PRORAMMING:

- 1 Turn the Ignition switch 'ON/OFF' 3 TIMES and stay in OFF position.
- 2 Push the Valet switch 6 times and hold it until three chirps and a long chirp is hearing then release the valet switch. You are now in the Alarm feature 'III' programming mode.
- 3 Press and release the transmitter button 'A' corresponding to the feature 'A' you want to program.

Press Transmitter Button	One Chirp / LED one pulse Factory Default Setting	Two Chirps / LED two pulse	Three Chirps / LED three pulse

1 Button I	H1/4 Brown Wire = Siren Output	H1/4 Brown Wire = Horn Output	
2 Button II	H3/6 Gray Wire = Trunk (Channel 2) Output	H3/6 Gray Wire = Two Step Door Unlock Output	H3/6 Gray Wire = Pager Output
3 Button I + II	Car Jacking Off	Car Jacking On	

Exit: Turn Ignition to 'ON' position, or leave it for 15 seconds. A 3 long chirps to confirm exit.

OPERATION MANUAL

A. TRANSMITTER OPERATION:

Transmitter Button	System Function	Remark
Button I	Arm / Lock door	
Button I – I	Arm and Delete Optional Sensor	Press twice.
Button I	Car Locator	System in Armed
Button I for 3 seconds	Panic function	Press 3 seconds
Button II	Disarm & Unlock Door	
Button II – II	Two Steps Door Unlock & Disarm System	Press twice within 3 seconds.
Button II for 2 seconds	Disarm & Pop Trunk Release	Press 2 seconds
Button I + II	Silent Arm / Disarm	Ignition in "off" position.
Button I + II for 2 seconds	Activate Anti Car-Jacking	Ignition in "on" position.

B. LED INDICATOR:

LED	Function
Off	Disarmed
Slow flash	Armed
Fast flash	Passive arming
On (solid)	Valet mode

LED	Function
2 flashes... pause	Trigger on trunk/hood
3 flashes... pause	Trigger on door switch
4 flashes... pause	Trigger on Dual Zone Shock Sensor
5 flashes... pause	Trigger on Ignition switch

C. CHIRP INDICATORS:

Chirp	Function
1 chirp	Arm
2 chirps	Disarm
3 chirps	Defective reminder
4 chirps	Disarm / Intrusion
6 chirps	Car Locator

D. PARKING LIGHT:

Parking light	Function
1 flash	Arm
2 flashes	Disarm
3 flashes	Disarm / Intrusion
12 flashes	Car Locator

E. ALARM OPERATING CONDITION:

	Siren	Parking Light	LED	Doors	Starter disable	Pager
1. Arming	1 Chirp	1 Flash	Slow flash	Locking	On	
2. Disarming	2 or 4 Chirps	2 or 3 Flashes	Off or Fast flash	Unlocking	Off	
3. Trigger	Alarming	Flashes	Slow flash		On	On
4. Panic	Alarming	Flashes	Slow flash	Locking	On	

F. ACTIVE ARMING – LOCK & ARM:

1. Press button I on transmitter.
2. The siren will chirp once and parking light will flash once indicating that the system is now armed. The vehicle's door will lock upon arming when interfaced with the security system.

Note: Defective sensor reminder: If the siren sounds 3 chirps, then you have left a door, trunk, or hood lid ajar. (See Feature "I - 3 Programming")

SILENT ARMING / DISARMING: Press the button I + II together on the transmitter will arm or disarm your security system, No chirp sound will be heard, arm / disarm confirmation will be through the vehicles parking lights only.

SHOCK SENSOR / OPTIONAL SENSOR BY-PASS: Press the button I on the transmitter twice within 3 seconds will arm the security system, by-pass the shock sensor and the optional sensor connected to 4 pin plug. The system will chirp one additional time to confirm the sensor bypass mode was activated. The sensor bypass feature is programmed to activate for one arming cycle only. The security system will return to normal operation during the next arming cycle.

G. PASSIVE ARMING: (See Feature "II - 2" Programming)

Active arming / disarming is controlling your security system via the remote transmitter. This security system is equipped with an optional Passive Arming feature, which allows the security system to arm 30 seconds after the last door is closed. Operation is as follows.

1. Turn the ignition to the "OFF" position and exit the vehicle.

2. After all entrances are closed, the security system LED will flash fast for 30 seconds. If you reopen any door / hood / trunk, the security system LED will stop flashing. It will begin flashing again once the vehicle all entrances are closed.
3. After 30-second time has elapsed, the security system will automatically "ARM". The siren will chirp [1] time and the parking lights will flash [1] time.

PASSIVE DOOR LOCKING: (See Feature "II - 2" Programming)

The vehicle's door will automatically lock after passive arming cycle has been completed.

H. ACTIVE DISARMING – UNLOCK & DISARM:

1. Press the button II on the transmitter.
2. The siren will chirp twice and parking light will flash twice to indicating that the security system is now disarmed. The vehicle's door will unlock disarming when interfaced with the security system.

TAMPER DISARMING: If alarm triggered, upon disarm the system, siren chirp 4 times, parking light flash 3 times.

TWO STEP DOOR UNLOCK: (See Feature III – 2 Programming.) This feature will independently unlock the driver's door only when disarming the security system. Pushing the button II on the transmitter two times within 3 seconds will unlock the entire vehicle.

AUTOMATIC RE-ARM (See Feature "I - 2" Programming): If this feature is selected, the security system will automatically re-arm itself 60 seconds after disarming with remote transmitter. Automatic rearm will cancel if any door is opened before the 60 seconds timer has elapsed.

I. DISARMING WITHOUT A TRANSMITTER

The Override function may be used if the remote transmitter is lost or inoperative.

1. Enter the vehicle and turn the ignition switch to 'ON' position. (Alarm will sound.)
2. Within 10 seconds push and release the valet switch

The alarm will stop sounding and enter the disarm mode. You can now start and operate the vehicle normally.

J. VALET MODE:

The valet switch allows you to temporarily bypass all alarm function, eliminating the need to hand your transmitter to parking attendants or garage mechanics. When the system is in valet mode, all alarm function are bypassed, however the remote panic feature and remote door lock will remain operational.

Enter Valet Mode:

1. Turn the ignition to "ON" position.
2. Push and hold valet switch for 2 seconds until the LED turns on. The LED will remain on as long as the system is in 'valet mode.

Exit Valet Mode:

1. Return to normal operation, turn ignition 'ON'.
2. Push and hold valet switch for 2 seconds, The LED will turn off indicate the system are exiting the valet mode.

K. PANIC FUNCTION:

The transmitter can be used as a remote panic switch to manually trigger the alarm in case emergency.

1. Press and hold the button I on the transmitter for 3 seconds. The alarm will immediately sound.
2. To stop the alarm, press and hold the button I or II on the transmitter, the panic mode will be turned off immediately.
3. If the button is not pressed, the alarm will automatically stop after 30 seconds.

L. TRIGGER THE SYSTEM

When armed, your vehicle is protected as follows:

1. Light impact will trigger the warn-away signal. A long chirp from siren/horn.
2. Heavy impact / Doors open / Hood open / Trunk open / Turns on the ignition switch will trigger the programmed sequence.

The starter disable relay (if installed) prevents the vehicle's starter from cranking. The siren and parking lights will turn on to alerting of an intrusion for 30 seconds. Then it will stop and automatic reset and re-arm. If the one of sensors or detectors still active, the alarm system will sound a maximum of 6 cycles of 30 seconds .

M. ANTI CAR-JACKING

Warning: If you don't need the anti car-jacking function in this alarm system, be sure to set anti car-jacking feature "OFF". This system is default setting all anti car-jacking "OFF". (See Alarm Feature III - 3 Programming.)

1. TRANSMITTER ACTIVATE THE ANTI CAR-JACKING:

Press and hold button I + II on the transmitter for 2 seconds while the vehicle's ignition is ON.

The parking light will turn on for 1.5 seconds to indicate trigger the anti car-jacking.

2. DOOR SWITCH ACTIVATE ANTI CAR-JACKING:

It operate as below:

1. Turn the ignition switch to "ON" position, the system is armed.

2. Once the system is armed, If you are forced from the vehicle, the system will activate the anti Car-jacking trigger when the door is opened and closed.

TRIGGER THE ANTI CAR-JACKING MODE:

3-timer circuits will function as follows:

First timer:

- a. 50 seconds after the system has been triggered. The siren will start chirping for 15 seconds.
- b. During this 15 seconds period of chirping, you will be alerting to push the valet switch once to turn off the anti car-jacking feature.
- c. If not, it will enter second timer anti car-jacking.

Second timer:

65 seconds after the system has been triggered. The siren starts alarming and the parking light starts flashing.

Third timer:

90 seconds after the system has been triggered

- a. The siren still alarming and the parking light flashing, and
- b. The starter disable will activate to prevent the vehicle from starting.
- c. It will remain active until the vehicle's battery power exhausted.

OVERRIDE THE SYSTEM TO TURN OFF ANTI CAR-JACKING:

Turn the ignition switch from OFF to ON, and within 10 seconds push valet switch, the siren will stop and the system disarmed

N. IGNITION CONTROL DOOR LOCKS. (See Feature II – 3 Programming.).

If the vehicle's door lock have been interfaced to the security system, the system will automatically lock the vehicle's door when the ignition is turned "ON" and /or unlock the vehicle's door when the ignition is turned "OFF".

O. TRUNK RELEASE. (See Feature III – 2 Programming.).

Press and hold button II on transmitter for two seconds to remote control the trunk release or other electric devices.

P. CAR LOCATOR

Under Arm situation press the button I on the transmitter to active car locator function. The siren will chirp 6 times. The parking light will flash 12 times, for you to easily locate your car.

This device complies with part 15 of the FCC rules. Operation is subject to the following two conditions.

- (1) This device may not cause harmful interference, and
- (2) This device must accept any interference received, including interference that may cause undesired operation.

